



SCRAPING TOOLS AND EQUIPMENT

BMS 220 RIDE-ON SCRAPERS

Ride-on models include the electric BMS 220E and the cordless BMS 220B. These ride-on floor removal systems are very maneuverable, especially in confined areas.

- 110 V electric system or rechargeable battery system
- Extremely quiet operation
- Comfortable to ride and drive
- Ergonomic controls for safe and easy maneuvering
- Precise hydraulic steering for exact maneuvering
- Large machine performance built into a compact machine
- Unique swivel head keeps blade in contact with the floor
- Sliding front plate allows for exact blade angle
- Great machines for commercial surface removal and preparation, yet compact enough for residential jobs



REMOVE THESE MATERIALS...

- Glued down flooring
- Commercial carpet
- Gummy adhesives
- VAT
- Solid vinyl
- Radial rubber tile
- Sheet rubber
- Indoor and outdoor sport surfaces
- Roofing material
- Rubber back

BMS 220B

- Cordless machine with replaceable battery
- Battery can be changed in minutes
- Rechargeable battery can be charged in or out of the machine, charges from 110 V
- Machine will keep running while the other battery pack is charging
- Battery doesn't take a "memory"—can be fully charged at any stage and still gives maximum battery life
- Unique battery design eliminates acid spilling compared to a regular lead acid battery

BMS 220E

- 110 V, electric system
- 1.5 h.p. continuous motors draw 13 amps
- Swiveling cord guide for easy management of cord location during operation
- Options include:
 - **Buck & boost transformer:** Increases line voltage out of receptacle, improving voltage by up to 20%. Use when wall outlet is under-voltage or excessive lengths of extension cords are used
 - **Voltage meter:** Easily plugs into any wall outlet to determine amount of voltage at that outlet



BMS 220 ACCESSORIES

BLADES

- Unique swivel head cutting head assemblies
- Swivel heads rotate to use the second sharp edge of the blade, without having to remove the blade
- Swivel head allows the blade to stay in contact with the floor
- Tough, durable construction
- Full range of head sizes to fit any job, from 6 to 27 inches
- Razor blade heads (in bold, right) are designed to hold razor blades. These sizes also available in cutting head assemblies
- Extension (for cutting heads) helps reach under tight areas

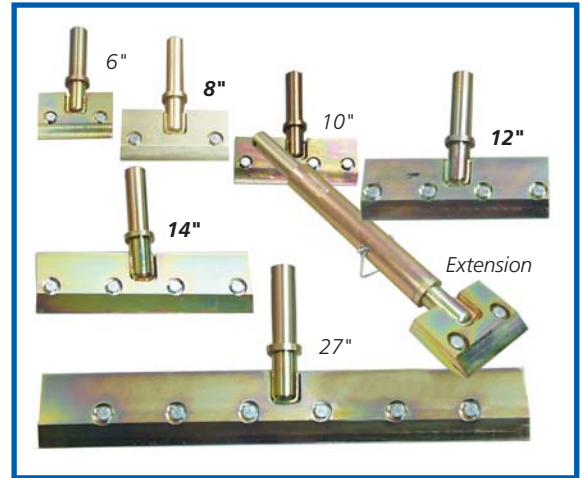

GENERAL ACCESSORIES

- **Tile box** assists for fast cleanup and collection of tile debris. High abrasion alloy for a long lasting edge
- **Front wheel assembly** allows stability and easier transportation over virtually any surface. Quick and easy to attach

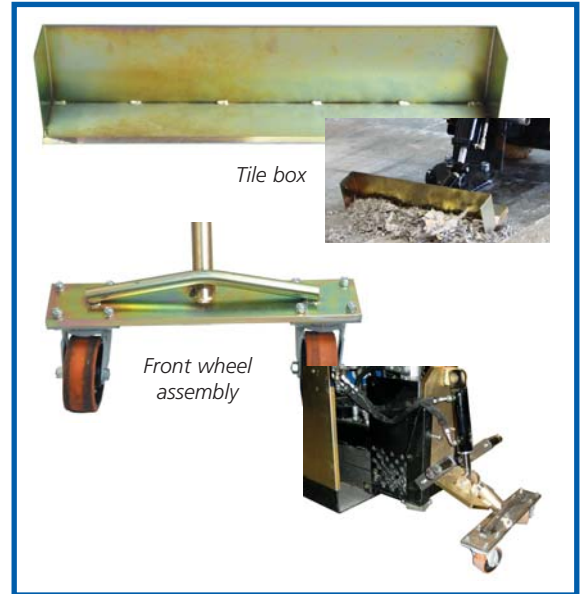

...AND MORE

- Woven unitary
- Enhancer
- Vinyl back
- Ceramic tile
- Thin-set mortar
- Hardwood parquet and plank flooring
- Epoxy
- Urethane
- Thick coatings



BATTERIES AND ELECTRICAL ACCESSORIES

- **Buck & boost transformer** increases the line voltage out of a receptacle, improving voltage by up to 20%. Use when wall outlet power is under-voltage or when using excessive lengths of extension power cords
- **Voltage meter** (not shown) plugs into any wall outlet to determine amount of voltage at that outlet
- **Battery packs** are removable and can be charged, so there's no down time. Not a lead acid battery: no acid spilling. Change packs in minutes by hand
- **Charger** is designed for demanding applications where performance and service are critical. Correctly charges for optimum battery life. Gives a complete charge in a short amount of time. Works off any 110 V receptacle

BMS 270: PROPANE POWER

BMS 270

The BMS 270 is a high-productivity, ride-on scraper designed for high volume removal.

- Liquid propane powered
 - Reduces time and effort required to remove a wide range of floor coverings and thick coatings
 - Particularly useful for **abatement jobs** prior to demolition, **outdoor applications**, and removing **waterproofing membranes** such as those found in parking structures
 - Easy to transport; size and weight allow access to most freight elevators
 - Fits through standard doorways
 - Comfortable seat and easy-to-use joystick controls
 - Easy maneuverability, small turning radius
- Operator friendly, skid steer controls, lighted work area, central direct-drive pump system, external battery terminals, easy access hydraulic filter assembly
 - Scraping blades available in 6 to 24 inch widths
 - Chipping teeth in 2 or 4 inch widths
 - Unique swivel head keeps blade in contact with the floor
 - Integral weight hangers accommodate up to 32 separate 42-pound weights (optional) for challenging removal applications



WALK-BEHIND SCRAPERS

Self-propelled, walk-behind scrapers are ideally suited for smaller jobs. These scrapers clean floors better than any other machines their size. Both the BS 75 and BS 110 systems include these features.

- Self-propelled 110 V systems; 220 V optional
- Orbital action for efficient removal
- Instant forward. Variable speed: 12 to 50 feet per minute
- Whisper-quiet, overload protected commercial motor
- Extremely quiet operation, can be operated on any job site
- Easy to operate, hand-controlled clutch for speed and safety
- Adjustable handle allows machine to reach into tight areas (such as under cubicle desks)
- Maintenance-free fluid drive
- Wheels disengage for easy transportation
- Easy to load and unload
- Durable, steel plate outer housing
- Options include additional weight, swivel head attachment



BS 75



BS 110

The BS 110 includes all the features above, plus these additional qualities:

- Heavier duty walk-behind unit
- Instant forward AND instant reverse for best maneuverability
- Secure mount, quickly detachable counterweight system
- Pin removes to disengage wheels for transportation
- Optional loading ramp



Swivel head allows blade to stay in contact with the floor. Rotates to use second sharp edge on blade, without removing blade. Holds razor/scrapper blades.



Easy to load and unload with optional ramp

SPECIFICATIONS

	BMS 220E	BMS 220B	BMS 270	BS 110	BS 75
Production Capacity*					
VCT:	3,125 sq. ft./hr.	3,437 sq. ft./hr.	1,000–3,500 sq. ft./hr.	42 sq. ft./hr.	42 sq. ft./hr.
Carpet:	1,500 sq. ft./hr.	1,650 sq. ft./hr.	2,000–7,000 sq. ft./hr.	42 sq. ft./hr.	42 sq. ft./hr.
Adhesives:	5,000 sq. ft./hr.	5,500 sq. ft./hr.	200–600 sq. ft./hr.	42 sq. ft./hr.	42 sq. ft./hr.
Sheet Vinyl:	1,000 sq. ft./hr.	1,100 sq. ft./hr.	1,000–3,000 sq. ft./hr.	42 sq. ft./hr.	42 sq. ft./hr.
Hardwood:	300 sq. ft./hr.	330 sq. ft./hr.	Parquet tiles	20 sq. ft./hr.	N/A
Coatings:	300 sq. ft./hr.	330 sq. ft./hr.	300–1,000 sq. ft./hr.	42 sq. ft./hr.	42 sq. ft./hr.
Ceramic Tile:	175 sq. ft./hr.	193 sq. ft./hr.	N/A	N/A	N/A
Travel Speed:	0–113 ft./min.	0–120 ft./min.	0–250 ft./min.	12–50 ft./min.	12–50 ft./min.
Voltage:	110 V, 1ø, 60 Hz	Battery unit	Liquid propane unit	110 V, 1ø, 60 Hz	110 V, 1ø, 60 Hz
Amperage:	13 A	Battery unit	Liquid propane unit	13 A	10 A
Dimensions (LxWxH):	50" x 24.5" x 39.5"	51" x 25" x 44.5"	76" x 30" x 64"	27.5" x 13" x 41"	25.5" x 11.5" x 38.5"
Weight:	1,000 lb.	1,150 lb.	2,590 lb.	360 lb.	207 lb.

* Production rates achieved are affected by variables specific to each job site. These figures are not guarantees of performance.

Always wear respirator protection, appropriate for the application, as specified by OSHA regulations and your employer. Never operate or maintain equipment before reading and understanding the instructions for operation and maintenance. Obey all safety signs and instructions while operating or maintaining equipment.



Blastrac offers a full range of surface preparation technologies



800-256-3440 • fax 800-547-5838 • blastrac.com

Products manufactured and marketed by Blastrac, NA are protected by patents issued or pending in the United States and other countries. Blastrac, NA reserves the right to change the specifications referred to in this literature at any time, without prior notice. Blastrac is a registered trademark owned by Blastrac, NA.